

KOHLER® Diesel

Model KDW2204

High-Speed Open Power Unit

4 Cylinders • 2199 cc • 38 kW/51.1 hp • 3000 rpm • 106.2 ft lbs @ 2000 rpm

Certification

- EPA Interim TIER 4
- 97/68/CE
- ECE R24-03

Features

- 4-Stroke Diesel Engine
- Liquid-Cooled with Axial Fan
- Indirect Fuel Injection
- Double PTO on the Crankshaft
- Counterclockwise Rotation (PTO Side)
- Full-Pressure Lubrication
- Automatic Extra-Fuel Starting Device
- Full-Flow Oil Filter
- Variable-Speed Governor
- Cast-Iron Crankcase with Reborable Cylinders
- Cast-Iron Cylinder Head
- Torque Device
- Hydraulic Valve Lifters

Applications

- Excavator
- Forklift
- Utility Vehicle
- Generator
- Aerial Platform
- Compressor
- High-Pressure Cleaner
- Sweeper
- Pump
- Tractor

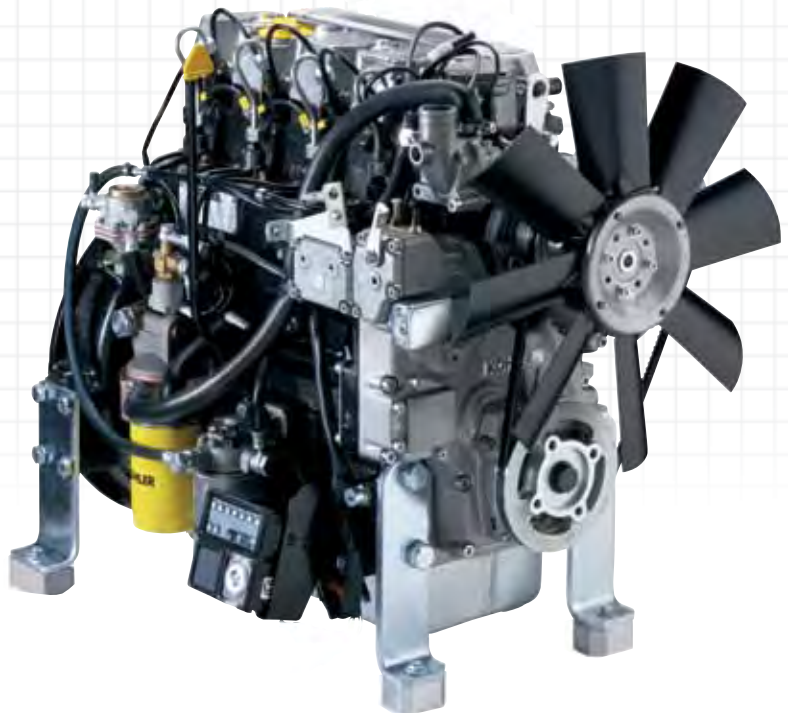

KOHLER® Diesel

Model KDW2204

High-Speed Open Power Unit

Specifications

Cylinders	No. of Cylinders	4
Displacement	cc/cu in	2199/134.2
Bore	mm/in	88/3.5
Stroke	mm/in	90.4/3.6
Compression Ratio		22.5:1
Rating kW/hp	N (80/1269/CEE) ISO 1585	38.0/51.0
	NB ISO 3046 IFN	34.5/46.3
	NA ISO 3046 ICXN	32.0/42.9
Maximum Torque	Nm/ft lbs @ 2000 rpm	144/106.2
Maximum Torque 3 PTO	Nm/ft lbs	39.2/29
Minimum Idling Speed rpm		900
Water Pump Delivery @ 3000 rpm	liters/min/gpm	100/26
Oil Consumption	kg/h/lb/h	0.025/0.055
Oil Capacity		
with Dynamic Horizontal Stabilizer	liters/quarts	4.5/4.8
without Dynamic Horizontal Stabilizer	liters/quarts	5.7/6
Maximum Allowable Angle of Operation (Peak Values)		25° (35°)
Volume of Air Required for Correct Combustion @ 3000 rpm	liters/min/cfm	3300/117
Volume of Air Required for Correct Cooling @ 3000 rpm	m ³ /min/cfm	128/4520
Dry Weight	kg/lb	214/472
Recommended Minimum Battery Size	V/CCA Standard, Heavy-Duty	12/660, 900
Minimum Pulley Diameters for Belt Drive		

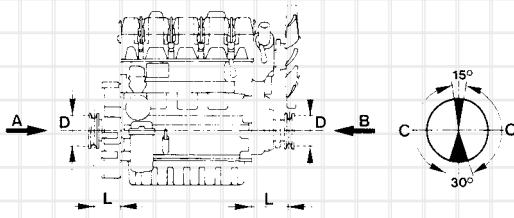

V-Belt	D (mm) ≥ 73 [L (mm) + 118]	N (kW)
		n (rpm)
Cogged	D (mm) ≥ 46 [L (mm) + 118]	N (kW)
Belt		n (rpm)
Maximum Allowable Axial Load in Both Directions		
A-B=300 kg/661 lb C - Allowable Zone for Radial Load		

Sound Pressure Level dBA
 Sound Pressure Level Polar Diagram
 Open Field at 7 Meters –
 No Load Running Engine

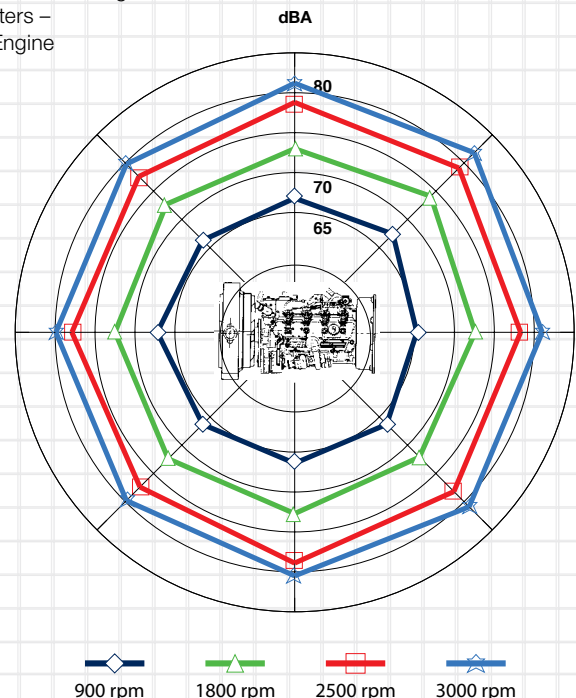

KOHLER® Diesel

Model KDW2204

High-Speed Open Power Unit

Curves

KDW2204 B1 @ 2800 rpm ■ ● ▲

KDW2204 @ 3000 rpm ■ ● ▲

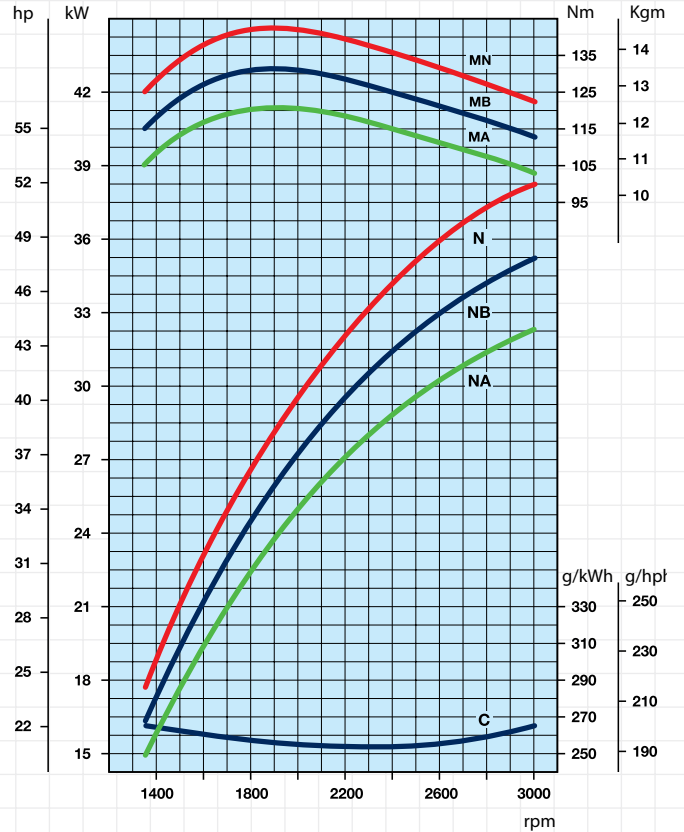
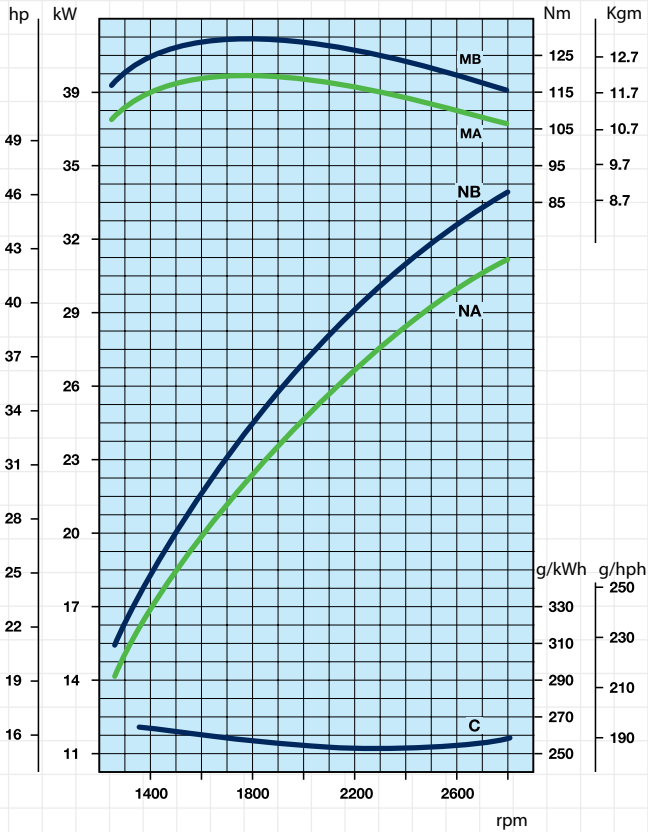

- N** Power Curve – 80/1269/CEE – ISO 1585
- NB** Power Curve – ISO 3046/1 – IFN
- NA** Power Curve – ISO 3046/1 – ICXN
- MN** Torque Curve – (N Curve)
- MB** (B Curve) – **MA** (A Curve)
- C** Specific Fuel Consumption – (NB Curve)

Output Power for Fixed-Speed Application
(Including Generator Sets)

Engine Power kW

rpm	Intermittent (NB)	Continuous (NA)
3000	35.0	31.8
1800	22.5	20.5
1500	19.5	17.7

KOHLER® Diesel

Model KDW2204

High-Speed Open Power Unit

Technical Drawings

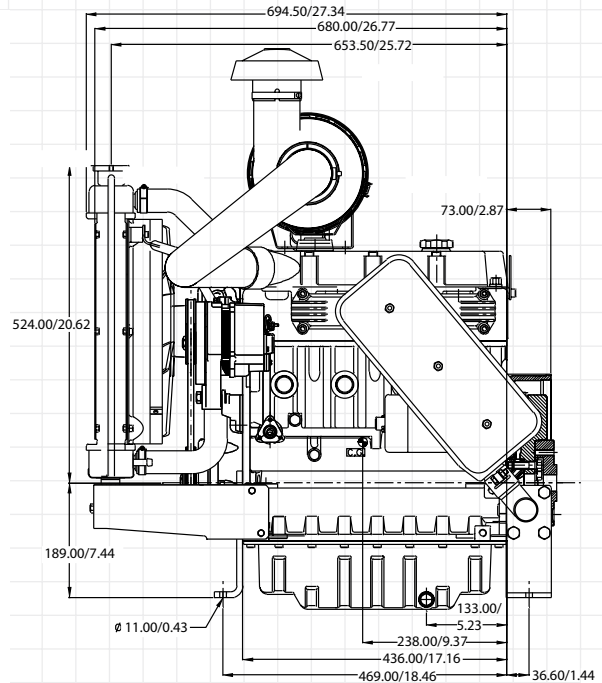
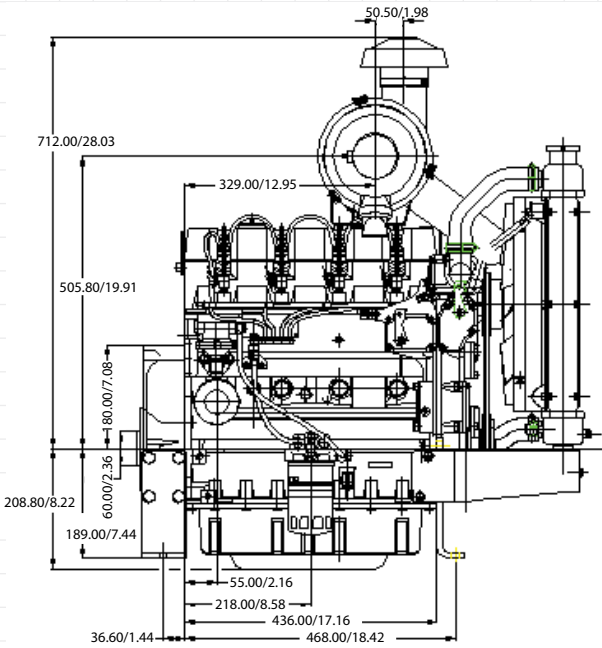

Standard Features (Open Power Unit)

- Base Engine
- Radiator Fan Guard
- Mounted Air Cleaner
- 12 V Electric Starter
- Fuel Filter with Valve
- Mounted Control Panel
- 3000 rpm
- Mounted Top Tank Radiator
- Suction Fan
- Muffler and Guard
- 45 Amp External Alternator
- Mounting Feet
- Group 5 Interchange Housing
- Safety Shutdown Low Oil Pressure and High Coolant Temperature

Accessories

- Optional Charging Systems
- SAE Housings and Drives
- Shaft Extensions
- Hydraulic Drives
- Dry Air Cleaners
- Various Mufflers and Manifolds
- Various Muffler Guards and Flanges
- Remote Oil Filter
- Top Tank and Crossflow Radiators
- Suction and Pusher Fans
- High-Capacity Oil Sump
- 2nd PTO Two-Groove Pulley
- Wiring Harness Extension
- Extended Dipstick

