

Kohler® Diesel

Model KD477-2

2 Cylinders » 954 cc » 16.2 kW/21.7 HP » 3600 RPM » 40.6 ft. lbs. @2200 RPM

Certification

EPA TIER 4 ▲

Features

- 4-Stroke Air-Cooled Diesel Engine
- Direct Injection
- Flywheel Fan Air Cooling
- Mechanical Fuel Pump
- Full-Pressure Lubrication with Gear Pump
- Full-Flow Oil Filter
- Automatic Extra Fuel Starting Device
- Variable Speed Governor
- Aluminum Crankcase
- 12 V Electric Starter
- Counter-Clockwise Rotation (From PTO Side)
- Aluminum Alloy Independent Heads
- Re-Borable Independent Cast-Iron Cylinders
- Power Take-Off on Crankcase

Applications

- Power Buggy
- Vibrating Roller
- Generator
- Welder
- High-Pressure Cleaner
- Hydraulic Power Pack
- Agricultural Pump
- Two-Wheel Tractor



Kohler® Diesel Model KD477-2

Specifications

Cylinders	No. of Cylinders	2	
Displacement	cc/cu. in.	954/58.2	
Bore	mm/in	90/3.5	
Stroke	mm/in	75/3	
Compression Ratio		19:1	
Rating kW/HP	N (80/1269/CEE) ISO 1585	16.2/27.1	
	NB ISO 3046 IFN	15/20.1	
	NA ISO 3046 ICXN	13.7/18.4	
Max. Torque	N-m/ft. lbs. @ 2200 RPM	57.5/40.6	
Max. Torque 3 PTO	N-m	25/18.4	
Counterclockwise Rotation			
Engine Speed - 3 PTO Ratio		1:0.89	
Minimum Idling Speed RPM		1000	
Fuel Tank Capacity	liters/quarts	7/7.4	
Oil Consumption	kg/h/lb/h	0.011/0.024	
Oil Capacity	liters/quarts	3/3.2	
Min. Allowable Oil Pressure	bar/psi	0.8/11.6	
Max. Allowable Angle of Operation (Peak Values)		25° (35°)	
Volume of Air Required for Correct Combustion @ 3600 RPM	liters/min/cfm	1500,1220/53,43	
Volume of Air Required for Correct Cooling @ 3600 RPM	liters/min/cfm	15800,13200/558,466	
Dry Weight	kg/lbs.	78/172	
Recommended Battery	V/Ah	12/55	
Axial Load	(continuous)	kg/lbs.	100/220
	(intermittent)	kg/lbs.	350/772

Minimum Pulley Diameters for Belt Drive

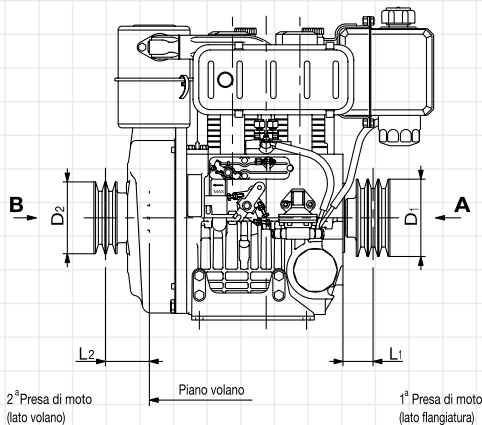

$$D_1 \text{ (mm)} \geq 220 [78+L_1 \text{ (mm)}] \frac{N \text{ (kW)}}{n \text{ (RPM)}}$$

$$D_2 \text{ (mm)} \geq 196 [150+L_2 \text{ (mm)}] \frac{N \text{ (kW)}}{n \text{ (RPM)}}$$

Max. allowable axial load in both directions A-B = 350 kg/772 lb_f

Sound Pressure Level dB (A)

Sound Pressure Level Polar Diagram Open Field at 7 Meters - No Load Running Engine.

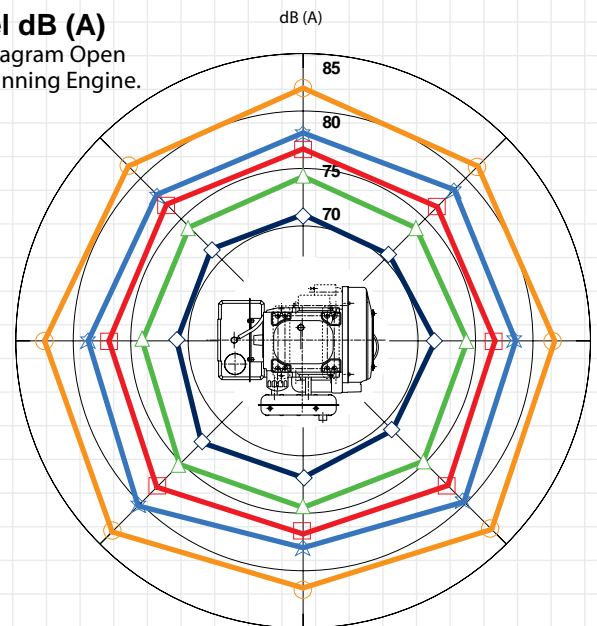

1500 RPM 2000 RPM 2500 RPM 3000 RPM 3600 RPM

Kohler® Diesel Model KD477-2

Curves

KD477-2 B1 @ 3000 RPM ▲

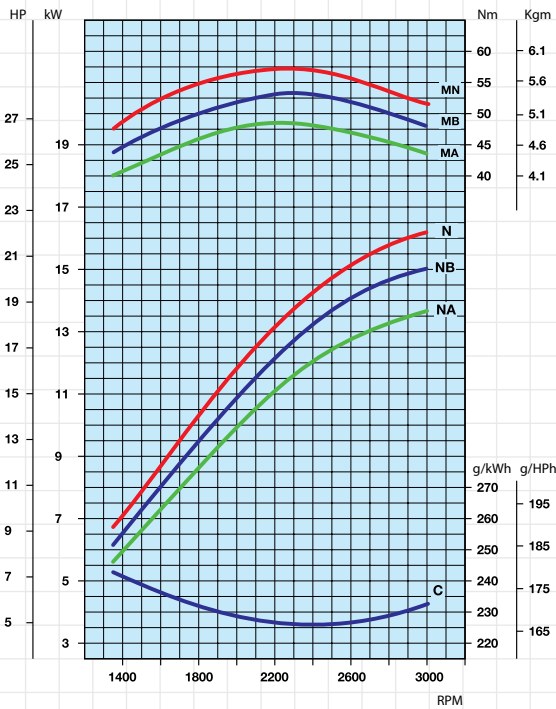

KD477-2 B2 @ 2800 RPM ▲

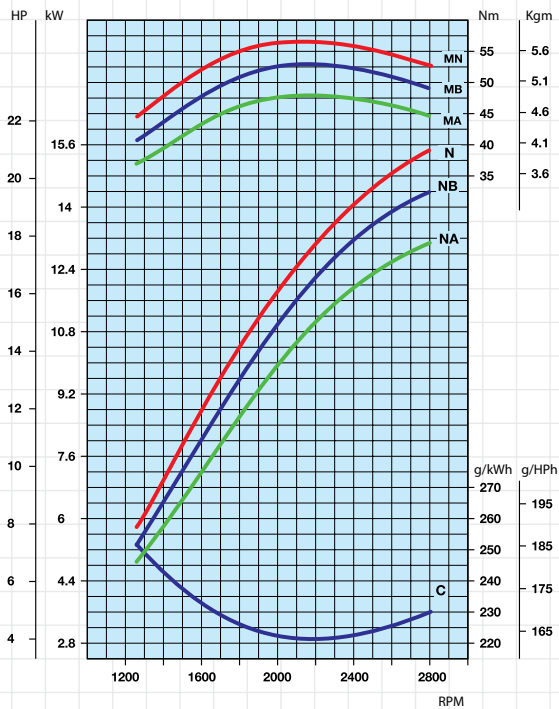

KD477-2 @ 3600 RPM

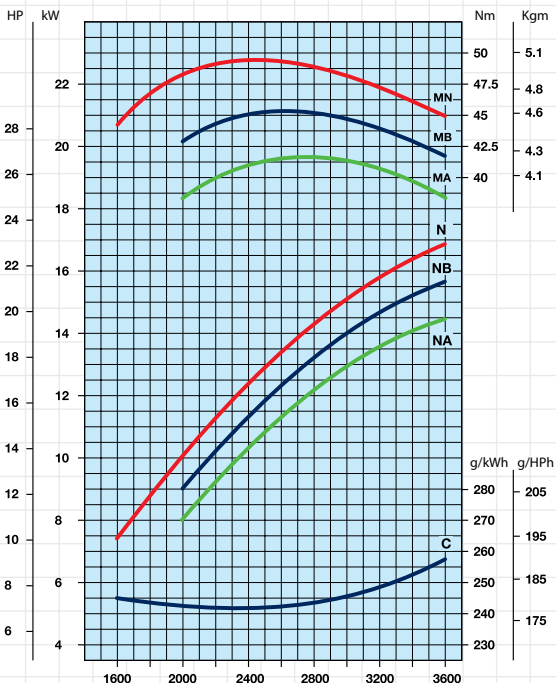

- N Power Curve - 80/1269/CEE - ISO 1585 -
- NB Power Curve - ISO 3046/1 - IFN -
- NA Power Curve - ISO 3046/1 - ICXN -
- MN Torque Curve - (N curve)
- MB (B Curve - MA (A curve)
- C Specific Fuel Consumption - (NB curve)

Output Power for Fixed Speed
Application (Including Generator Sets)

Engine Power kW

RPM	Intermittent (NB)	Continuous (NA)
3600	15.7	14.5
3000	14.9	13.5
1800	9.0	8.1
1500	7.7	7.0

Kohler® Diesel Model KD477-2

Technical Drawings

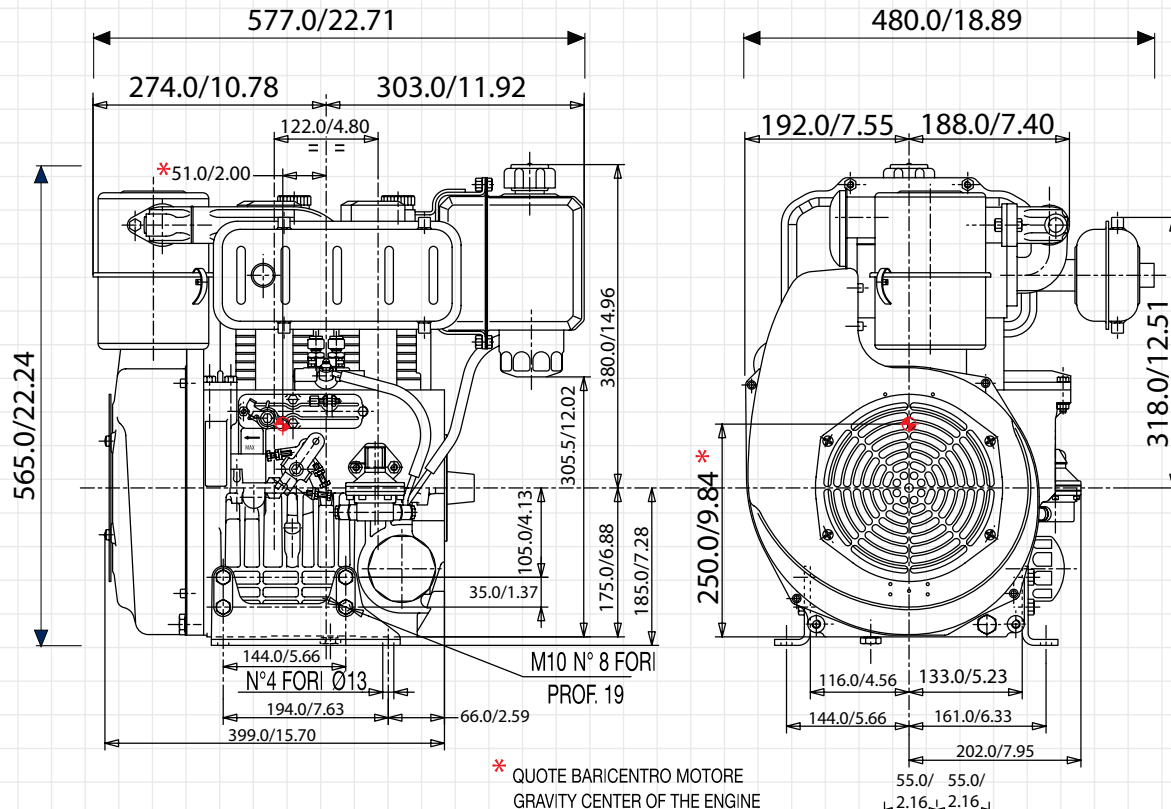

Standard Equipment

- Electric Start with 12 V Alternator
- Remote Throttle
- External Oil Filter
- Oil Pressure Switch
- Downward Muffler Angled Towards Flywheel End
- Engine Feet
- Power Take-Off on Crankshaft
- Keyswitch Panel
- Fuel Lift Pump
- Counter-Clockwise Rotation on Power Take-Off Side
- Automatic Extra Fuel Device
- 1-1/8" Dia. Keyed Integral Crankshaft with 7" Mounting Flange

Accessories

- Extended Wiring Harness
- SAE 2A-9T Hydraulic Pump Adapter
- SAE 5 Housing with 6-1/2" Flywheel

